

# Manchester Tool and Die Model M25 Deburr

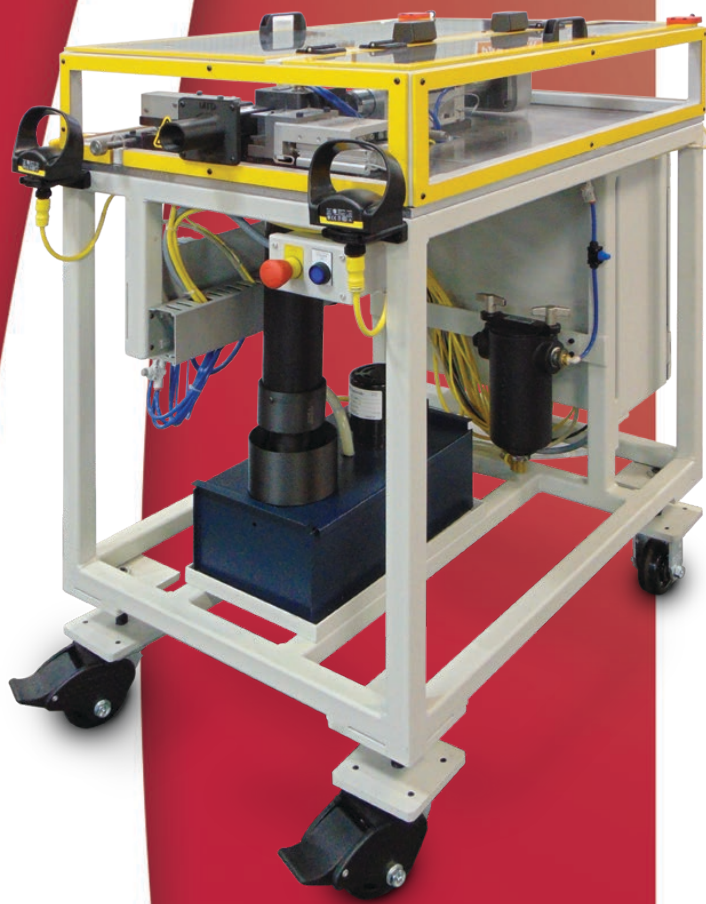

Manchester model M25 tube deburring and end-finishing machine is a manually-operated machine for simultaneous deburring and chamfering of a tube, rod, or pipe end.

The clamp and deburring head are pneumatically operated.

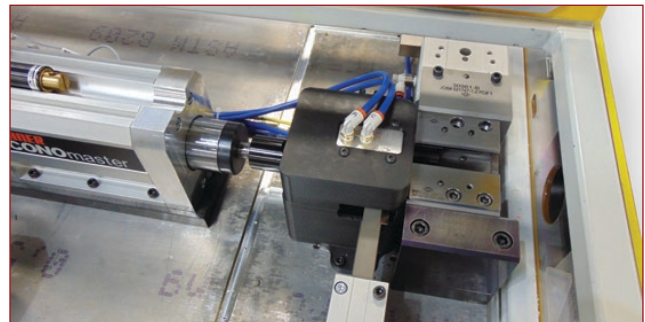
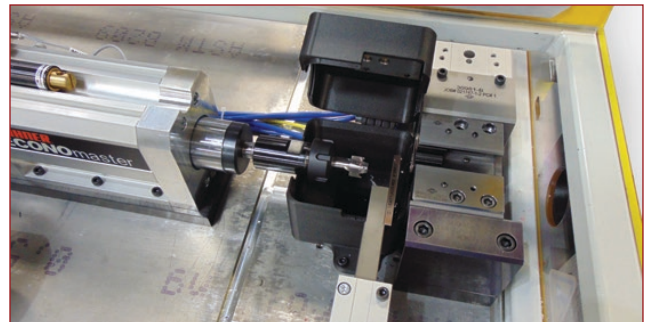

**Contact MTD for more information:**  
Call 260-982-8524 or email at [quotes@mtdbkb.com](mailto:quotes@mtdbkb.com)

[www.mtdtube.com](http://www.mtdtube.com)

# Model M25 DEBURR

## Tube Deburring and End-Finishing Machine

### MTD SPECIFICATIONS

#### Standard Equipment

- Floor layout dimensions: 29"W (737mm) x 43"L (1092mm) x 45"H (1143mm)
- Tube capacity: 3/16" to 1" (4-25mm)
- SMC pneumatics (80 psi, 3-4 cfm)
- Power requirements: 120 VAC / 60 Hz (20 amp)
- Pneumatically operated variable speed spindle unit with 3/4 HP motor
  - Forward adjustable hard stop
  - Hydraulic shock for forward final feed rate adjustment/fine tuning
  - Pneumatic flow controls
  - 250-700 RPM
- Built-in hood for debris containment and collection in bucket under machine
  - Air-blow nozzle to clear debris from the cutting tool
- Manually adjustable pneumatic part stop to locate tube in machine
- Zero force palm button for cycle activation
- Severance-style deburring/cutting tool
- Machine painted Sherwin Williams RAL7035 light gray in macropoxy paint
- Estimated cycle time: 2-3 seconds (dependent on application)

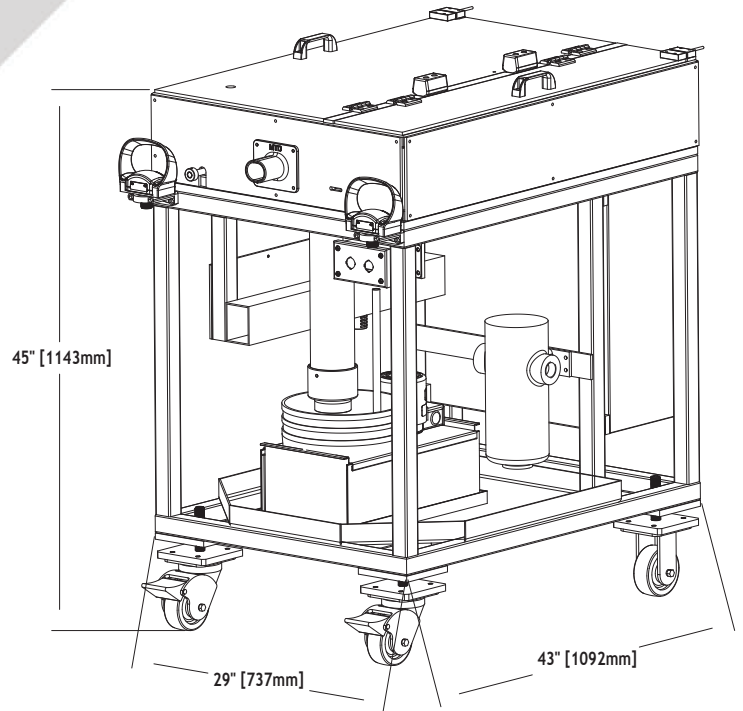

### VALUABLE OPTIONS

- Flooded coolant system for extending life of cutting tools
- Custom paint colors
- Foot switch
- C.E. certification

**Machine weight is approximately  
450 lbs (205 kg)**



Manchester Tool & Die, Inc. also works with the customer to create machines for unique applications.

#### Manchester Tool & Die, Inc.

P.O. Box 326 • 601 South Wabash Road • North Manchester, IN 46962  
Phone: 260-982-8524 • Fax: 260-982-4575  
Email: [quotes@manchestertoolanddie.com](mailto:quotes@manchestertoolanddie.com)

Exceeding Expectations Since 1960 • [manchestertoolanddie.com](http://manchestertoolanddie.com)