

Manchester Tool and Die

Model 60006

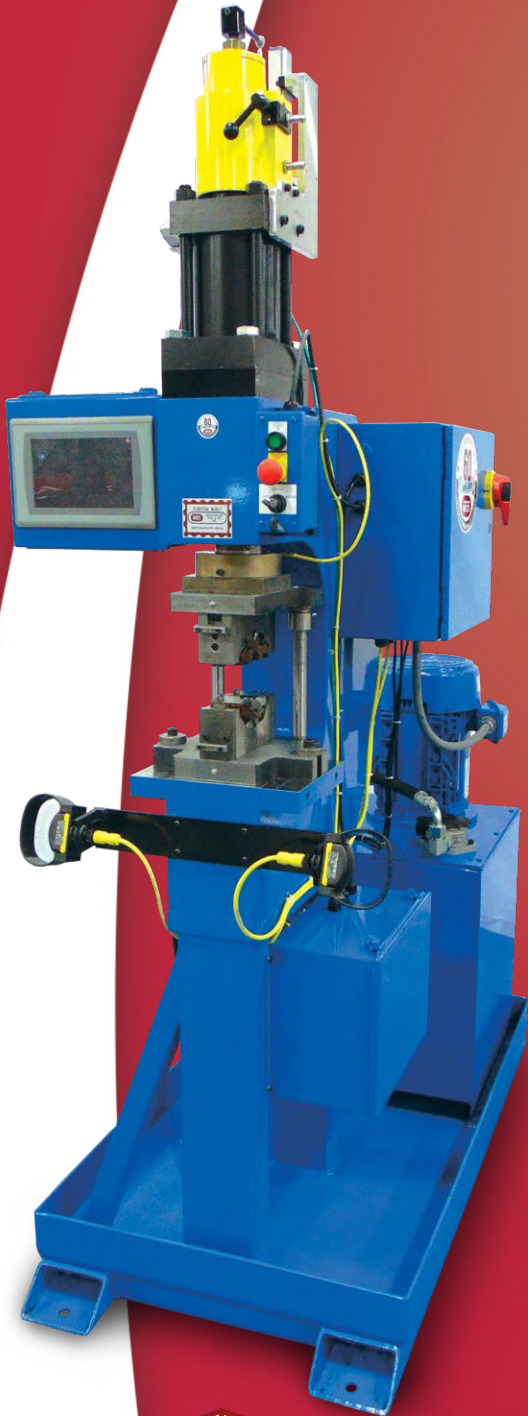

Model 60006 Econo-Crimper

Affordable crimping solution where higher-end machine is not needed.

- Compact footprint
- Allen-Bradley controller comes standard
- Adjustable ram stroke for totally optimized cycle time
- RAL5015 Sky Blue paint color, custom colors also available
- Many options available, including non/resettable parts counter and casters for easy mobility

The Econo-Crimper: available from stock. As always, MTD works with customers to provide custom solutions.

*Shown with optional force/position monitoring system and 64010 die set.

MTD

**MANCHESTER
TOOL & DIE,
INC.**

www.mtdtube.com

Manchester Model 60006 Econo-Crimper

MTD SPECIFICATIONS

Standard Equipment

- Ram Cylinder: 5" bore x 4" Stroke
- Rated Tonnage: 20 Tons at 2,425 PSI
- Advance Ram Speed: 181 IPM = 1.32 sec.
- Retract Ram Speed: 240 IPM = 1 sec.
- Open Height: 13.625"
- Throat: 5.75"
- Maximum Stroke: 4"
- Adjustable Ram Stroke
- Hydraulic Unit: 13 GPM
- Dual Zero-Force Touch Buttons/Anti-Tiedown
- Allen-Bradley IEC Controls
- Compact Footprint
- RAL5015 Sky Blue Paint Color
- Easy Access for Die Changeover
- 1 Year Manufacturer's Warranty

Valuable Options

- Force and Position Monitoring System
- Allen-Bradley Safety Light Curtains
- Crimp Component Fixturing
- Casters For Easy Mobility
- Resettable Parts Counter

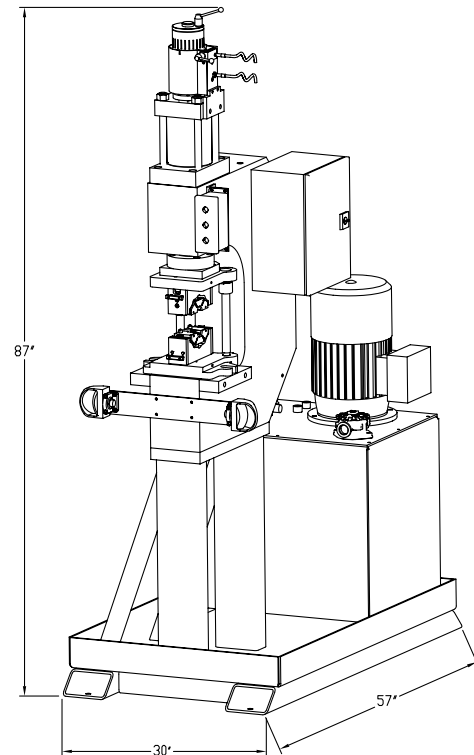

- Standard single-cavity crimp die shown below
- Double-cavity crimp die contains both a left and right crimping stations.
- Eliminates turning hose when crimping both ends of hose is required
- Crimp dies can produce either a four, six or eight segment crimp (multiple dies may be needed)
- Eight-segment dies are standard with our quick-change tools

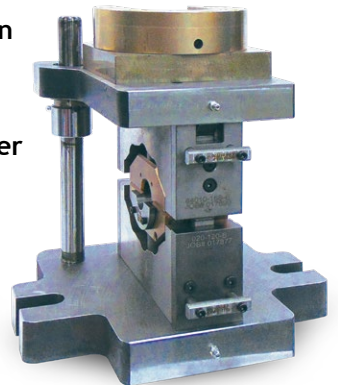

CALL FOR AVAILABLE STOCK MACHINES



Manchester Tool & Die, Inc. also works with the customer to create machines for unique applications.

Manchester Tool & Die, Inc.

P.O. Box 326 • 601 South Wabash Road • North Manchester, IN 46962
Phone: 260-982-8524 • Fax: 260-982-4575
Email: quotes@manchestertoolanddie.com

Exceeding Expectations Since 1960 • www.mtdtube.com